

**RADIALL®**

SOGIE DIVISION

SALES DRAWING

616 022

TITRE : SIZE 5 COAXIAL PIN CONTACT
FOR CABLE RG316 RG174 RG188 RG179

Edition : _____ Page _____

SERIE : DSX _____ / _____

PEN : _____

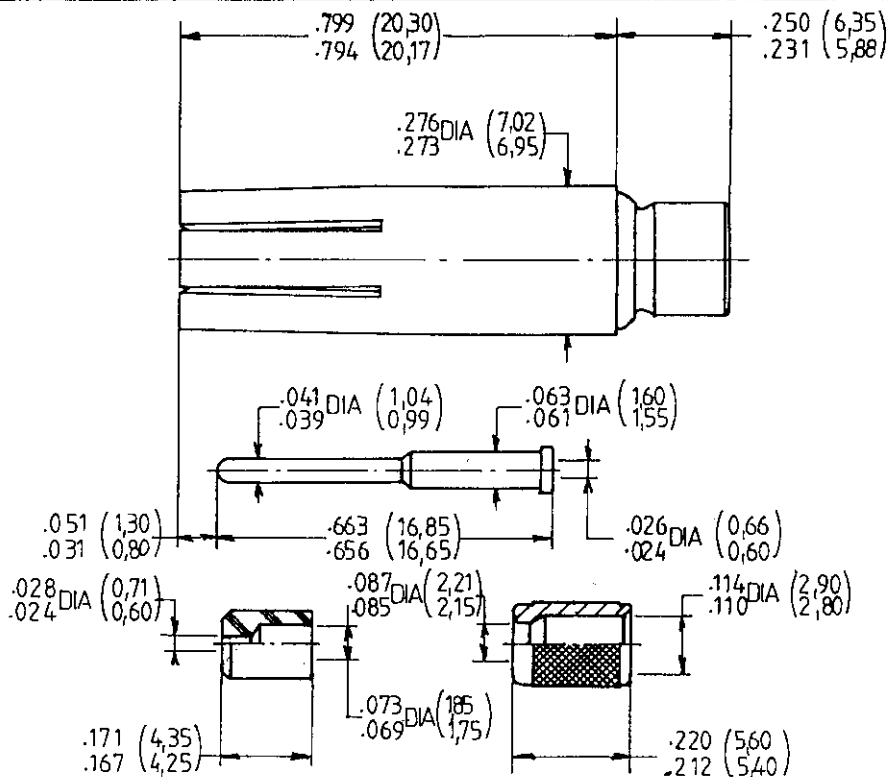

1°) Trim jacket to 10 mm (.394) dimension, then slide ferrule over braid, until it butts against the jacket. Comb out exposed braid.

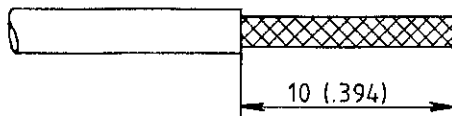

2°) Fold combed braid over ferrule. Trim dielectric to X dimension (see note) slide rear insulator on dielectric until it butts. Slide centre contact over conductor then solder (610 047-610147) or crimp (616123). Crimping tool M22520/2.01 (Radiall 282281) selector position 6, positioner Radiall 282974.

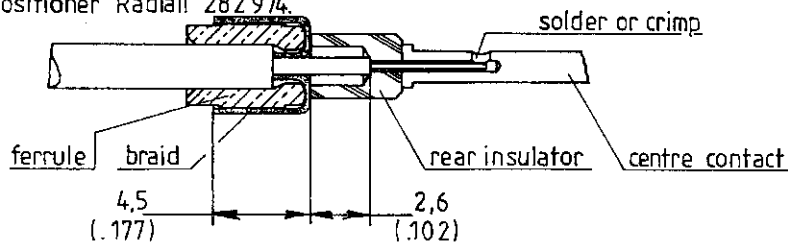

3°) Insert the part into body, ensuring they are pushed home, then crimp barrel. Crimping tool M22520/5.01 (Radiall 282293), die M22520/5.05 (Radiall 282246). Hex.: B

IND	MODIFICATIONS	DATE	VISA
Création	Date 9-7-89		
Mise à jour	Date _____		

Ces renseignements vous sont donnés à titre indicatif. Dans le but constant d'améliorer nos produits, nous nous réservons le droit d'apporter toutes modifications jugées utiles.



101, Rue Ph. Hoffmann - Z.I. Ouest
93116 ROSNY/S/BOIS Cedex (France)
Tel. : (1) 48 54 80 40
Fax : (1) 48 54 63 63
Telex: Radia A 220673 F